

## SCHOTTKY BARRIER RECTIFIER

VOLTAGE RANGE: 20 --- 200 V  
CURRENT: 20.0A

### FEATURES

- ◇ Metal-semiconductor junction with guard ring
- ◇ Epitaxial construction
- ◇ Low forward voltage drop, low switching losses
- ◇ High surge capability
- ◇ For use in low voltage, high frequency inverters free wheeling, and polarity protection applications
- ◇ The plastic material carries U/L recognition 94V-0

### MECHANICAL DATA

- ◇ Case: JEDEC ITO-220AB, molded plastic
- ◇ Terminals: Axial lead, solderable per MIL-STD-750, Method 2026
- ◇ Polarity: As marked
- ◇ Weight: 0.08 ounces, 2.24 grams
- ◇ Mounting position: Any

### ITO - 220AB

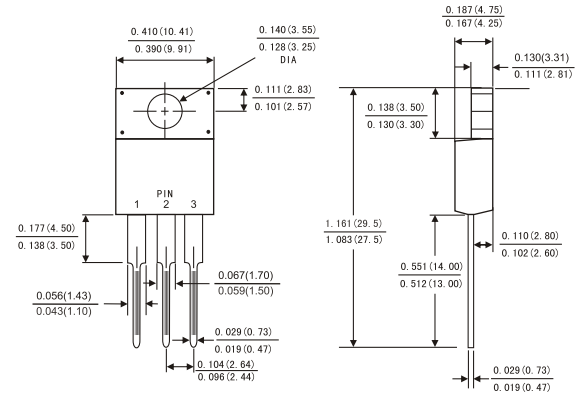

### MAXIMUM RATINGS AND ELECTRICAL CHARACTERISTICS

Ratings at 25°C ambient temperature unless otherwise specified.

Single phase, half wave, 60 Hz, resistive or inductive load. For capacitive load, derate by 20%.

	Symbols	MBRF 2020CT	MBRF 2030CT	MBRF 2040CT	MBRF 2050CT	MBRF 2060CT	MBRF 2080CT	MBRF 20100CT	MBRF 20150CT	MBRF 20200CT	Units	
Maximum repetitive peak reverse voltage	$V_{RRM}$	20	30	40	50	60	80	100	150	200	Volts	
Maximum RMS voltage	$V_{RMS}$	14	21	28	35	42	56	70	105	140	Volts	
Maximum DC blocking voltage	$V_{DC}$	20	30	40	50	60	80	100	150	200	Volts	
Maximum average forward rectified current (see Fig. 1)	Per leg	10.0									Amps	
	Total device	20.0										
Peak forward surge current 8.3ms single half sine-wave superimposed on rated load (JEDEC method)	$I_{FSM}$	200.0									Amps	
Maximum instantaneous forward voltage at 20.0 A	$V_F$	0.60			0.75		0.85		0.90		0.95	Volts
Maximum instantaneous reverse current at rated DC blocking voltage (Note 1)	$T_c = 25^\circ\text{C}$	0.2									mA	
	$T_c = 125^\circ\text{C}$	30			50							
Typical thermal resistance (Note 2)	$R_{\theta JC}$	3.0									°C/W	
Operating junction temperature range	$T_J$	-65 to +150									°C	
Storage temperature range	$T_{STG}$	-65 to +150									°C	

- NOTE: 1. Pulse test: 300us pulse width, 1% duty cycle.  
2. Measured at 1.0MHz and applied reverse voltage of 4.0V DC.  
3. Thermal resistance junction to ambient

**FIG.1-FORWARD CURRENT DERATING CURVE**

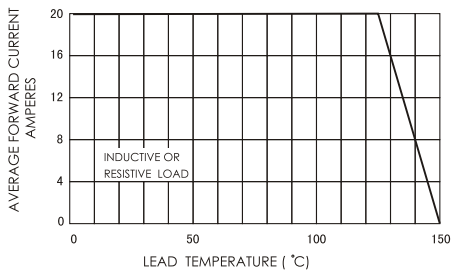

**FIG.2-MAXIMUM NON-REPETITIVE PEAK FORWARD SURGE CURRENT**

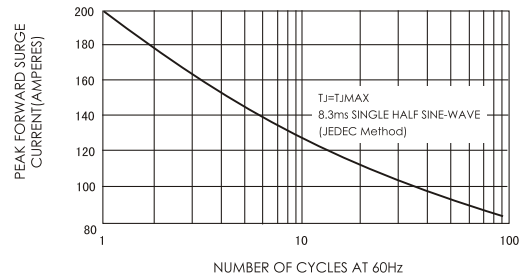

**FIG.3-TYPICAL INSTANTANEOUS FORWARD CHARACTERISTICS**

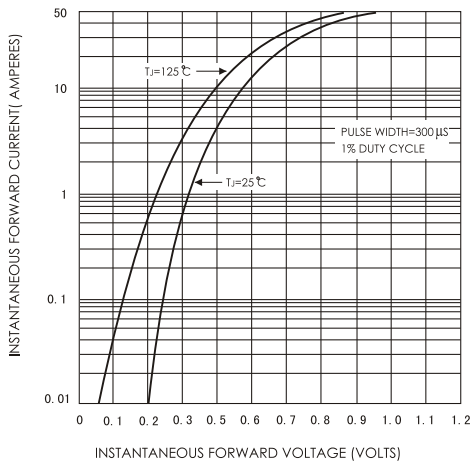

**FIG.4-TYPICAL REVERSE CHARACTERISTICS**

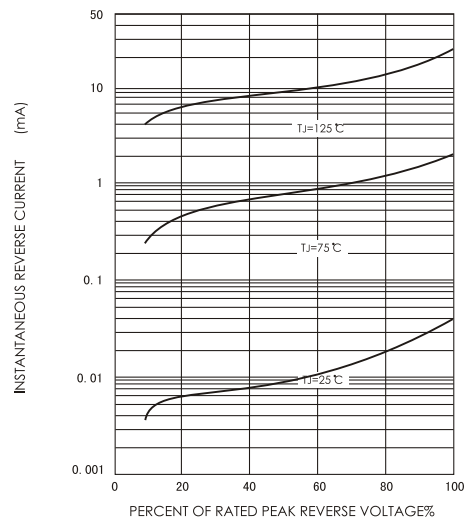

**FIG.5-TYPICAL JUNCTION CAPACITANCE**

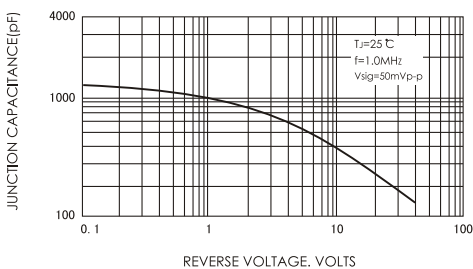

**FIG.6-TYPICAL TRANSIENT THERMAL IMPEDANCE**

